

TB043 (Rev2) - Connecting a TT-1/TT-2 or DP-4/DP-7 Probe and Potential TT-1 Field Issue

Overview

The connector plug on the following Centroid probes are correctly wired for the ***DIGITIZER PLUG*** input located in the Magnetics Cabinet. The most common mistake is to connect a probe into the MPG socket. This document will also cover a potential TT-1 problem out in the field that could lead to other problems.

Install

Plug the following probing devices into the ***Digitizer Plug*** input as shown in the diagram below.

TT-1 or TT-2 = Tool touch off block

DP-4 or DP-7 = Digitizing probe

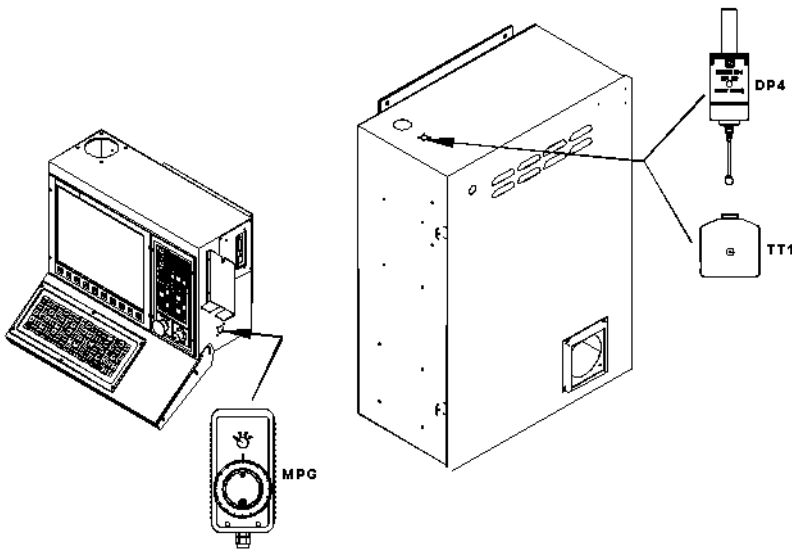

**** WARNING: DO NOT PLUG THE TT-1, TT-2, DP-4 OR DP-7 INTO THE MPG INPUT! ****

Setup and Operation

Refer to **Chapters 4 and 8** of the M-Series operator manual for information on setting up and using the TT-1 and TT-2 Tool Touch-off block or the DP-4 and DP-7 probe.

As of CNC7 v8.22 the TT1 or TT2 has its own parameter, 44, so that you can wire a second connector for the TT1 or TT2 and leave it connected all the time.

Important Note: If your TT device does not have a separate connector, make sure parameter 44 is set to 0 before using your TT1 or TT2. You **will** crash your TT device if P44 is set to a non-zero value and it's connected to the standard connector on the electrical cabinet.

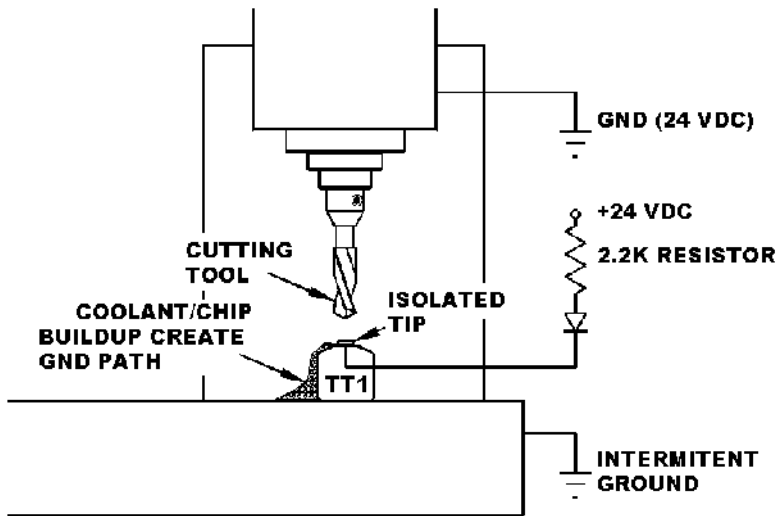

Potential Problems

- Coolant (conductive)/chip buildup on and around the TT-1 can cause false trips.
- Stale, dirty or "sour" coolant makes the short intermittent, which can overload the PLC and cause other erratic symptoms. The buildup only has to be approx. 2kohms to cause problems.
- Intermittent grounds can cause erratic operation and possible static or noise buildup, which in extreme cases come back through the encoders and take out the motion controller card.
- Tooling or spindle bearings are not conductive.

Solutions

- Cover the TT-1 when not in operation or remove from the worktable.
- If the TT-1 has a buildup, clean the TT-1 with a scotch-brite pad.
- Purchase a TT-2 to eliminate conductivity issues.

Document History

Rev2 Created on **2011-11-02** by **#270**

[Rev1](#) Created on **1999-09-09** by **#326**