

TB265 (Rev1) - Lash/Screw Compensation Acceleration Coefficients

Purpose:

To describe the use of the Lash/Screw Compensation Axis Acceleration Coefficient parameters, 208 thru 215, which were introduced and are used in CNC11 v3.02 and higher. This document assumes the reader is using a Renishaw ballbar and software to analyze the results of lash or screw compensation.

Background:

When screw compensation or lash compensation is enabled and setup correctly, a ballbar plot will show that backlash has been minimized. However, the lash/screw compensation may have produced anomalies seen on the ballbar plot as reversal spikes. These reversal spikes can be caused by having the speed of the lash/screw compensation either too fast or too slow. This document will serve as a guide on how to minimize reversal spikes caused by lash/screw compensation by adjusting parameters 208 thru 215.

Reversal spikes can be caused by other machine issues as well, such as excess friction or even servo drive issues. Parameters 208 thru 215 are not necessarily intended to solve these issues.

Technical:

The values of parameters 208 thru 215 are used to compute the acceleration rate which is used for the lash or screw compensation. Adjusting these parameters therefore effects the speed and time of the lash/screw corrections made by the motion processing unit for each individual axis. The acceleration rate for the axis also effects the speed of the lash/laser compensation. This acceleration rate is computed based on the acceleration time (from the PID menu settings) and the maximum velocity of the axis (from the Jog menu).

Prerequisites for adjusting parameters 208 thru 215:

- Parameters 216 and 217 should both be set to the recommended values of zero.
- Centroid PID values/3rd party drives have been properly tuned. (PID menu, see also third party drive documentation)
- All mechanical issues have been resolved.
- The correct maximum feedrates have been set for all axes. (Jog menu "Max Rate")
- The correct acceleration time has been set for all axes. (PID menu "Accel")
- Lash or screw compensation has been successfully setup so that backlash is minimized.

Procedure:

By default, the values for parameters 208 thru 215 are set to 0.1250. Unfortunately, there isn't an easy way to calculate the best values to use other than trial and error. The amount that the parameter will need to be changed will vary depending on the machine, the motors, the drive, the ballscrew, tuning, and other factors. The value of the parameter must be greater than zero for lash or laser screw compensation to work.

Negative reversal spikes:

Negative reversal spikes are an indicator that the lash/screw compensation corrections are performed too quickly. To minimize this effect, lower the value of the Acceleration Coefficient parameter for the axis with the reversal spikes. For example, if the parameter was originally set to 0.1250, try setting the parameter to 0.0125. Rerun the ballbar and see what effect this change made. The goal is to get the reversal spikes as close to zero as possible. Repeat this procedure of lowering the value until the goal is reached. If the reversal spikes have become positive, the parameter has been changed too far.

Positive reversal spikes:

The procedure for positive reversal spikes is the same as negative reversal spikes, except that the parameter value should be increased instead of decreased. For example, if the parameter was originally set to 0.1250 and the ballbar plot reported positive reversal spikes, try changing the parameter to 0.25 and rerun the ballbar.

Example barbar plots with negative reversal spikes:

The following barbar plots show the results of screw compensation on the X and Y axes.

In the plot below, the amount of backlash for X and Y have been minimized. However, the plot shows reversal spikes on the X axis. The value of parameter 208 was 0.1250 (default).

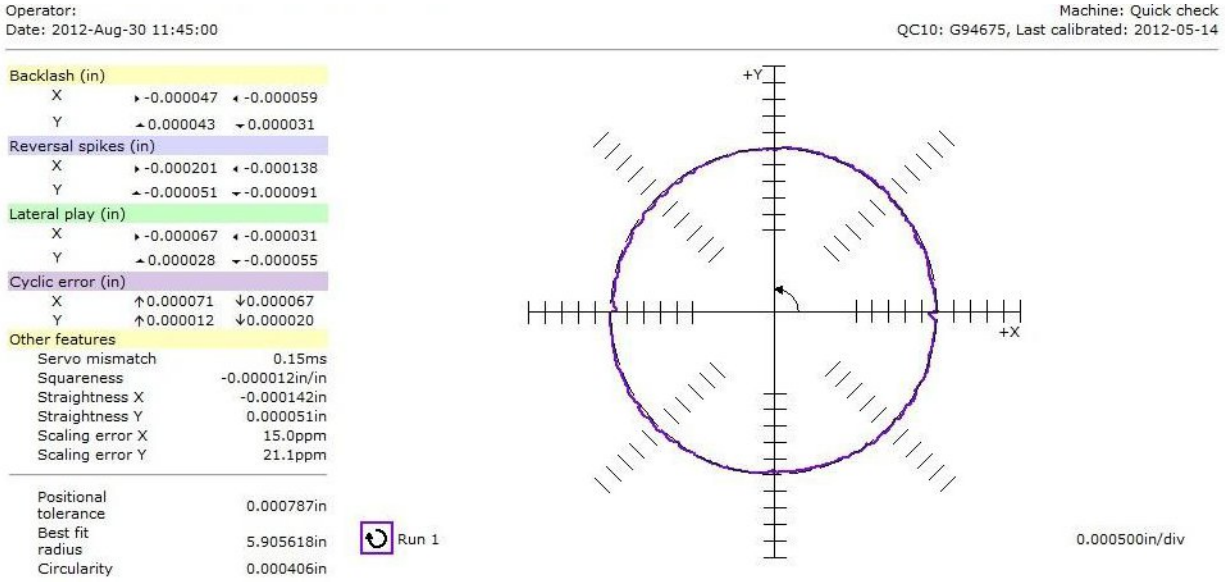

In the plot below, parameter 208 was changed to 0.00125 and the barball test was run again. The reversal spikes have improved.

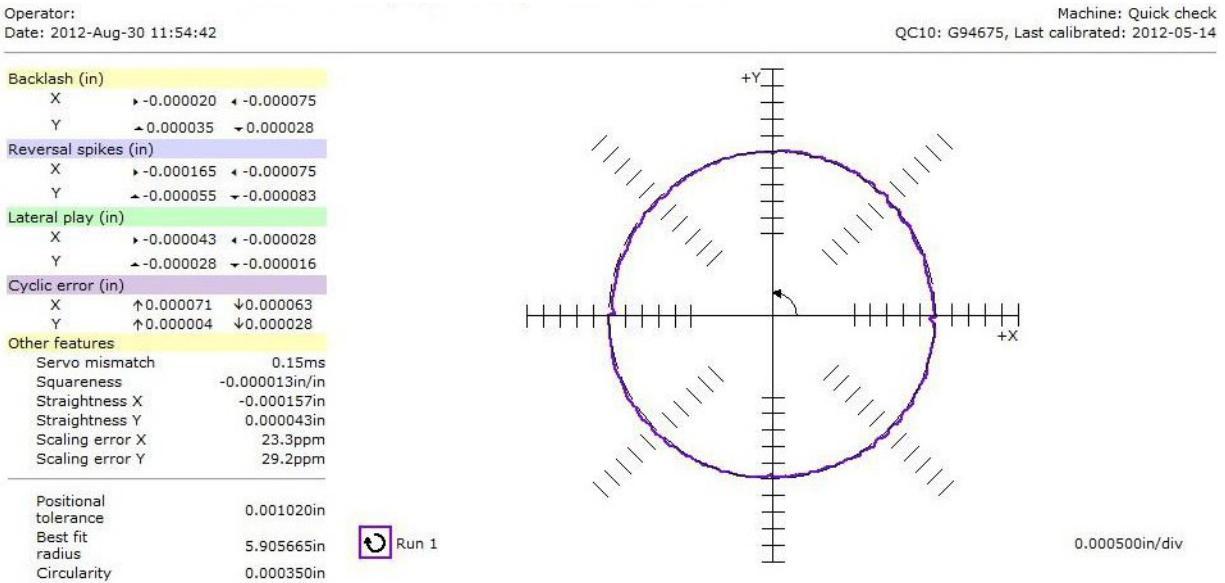

In the plot below, the value of parameter 208 was changed to 0.00013 and the barball test was run again. The parameter has been lowered too far causing the reversal spikes to swing to a positive value.

| Backlash (in) | | |
|----------------------|----------------|-------------|
| X | ▶ 0.000016 | ◀ -0.000039 |
| Y | ▲ -0.000043 | ▼ -0.000051 |
| Reversal spikes (in) | | |
| X | ▶ 0.000067 | ◀ 0.000106 |
| Y | ▲ -0.000051 | ▼ -0.000087 |
| Lateral play (in) | | |
| X | ▶ -0.000063 | ◀ -0.000043 |
| Y | ▲ -0.000000 | ▼ 0.000039 |
| Cyclic error (in) | | |
| X | ↑ 0.000071 | ↓ 0.000067 |
| Y | ↑ 0.000016 | ↓ 0.000012 |
| Other features | | |
| Servo mismatch | 0.14ms | |
| Squareness | -0.000012in/in | |
| Straightness X | -0.000138in | |
| Straightness Y | 0.000043in | |
| Scaling error X | 35.6ppm | |
| Scaling error Y | 43.8ppm | |

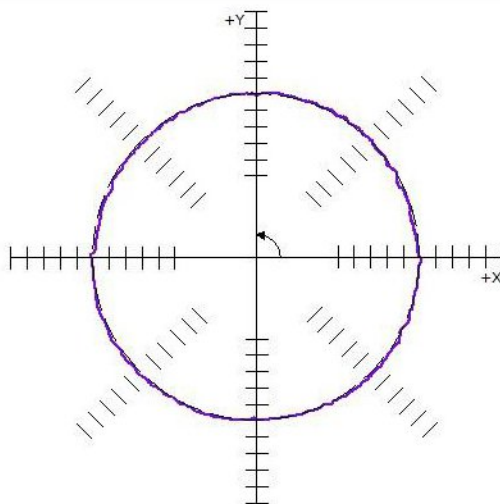

0.000500in/div

Document History

Rev1 Created on 2012-06-15 by #270