

TB025 (Rev1) - M15-5 Servo Troubleshooting

CHECK the Fault Indicator LED's - (normally all are lit)

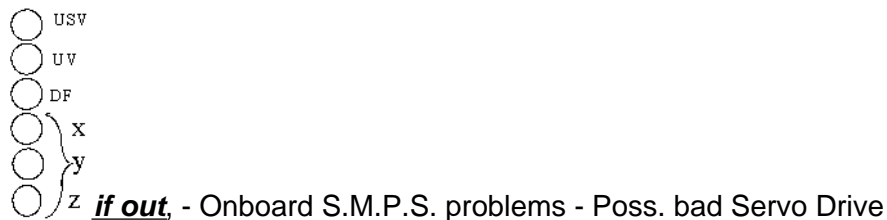

if out with USV, - Check E-STOP loop **Goto Step 5**

if out with USV and UV, - Check Fibers, **Goto Step 4**

ALL Red LED's should be lit until you jog any axis, then go out. **If no, goto note 2.** (To free axis again, @ MDI type M93)

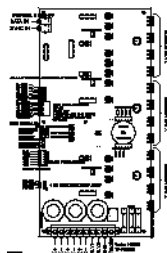

1. Check the **Status LEDs** (See above)

2. Eliminate **Power Box** - With the power off, on the main power cable coming out of the power box, jumper a wire across pins 6 and 2.(see Diagram 1) Turn the power on and press the red reset button. With a multi-meter, test between pin 3 - (**ground**) and pin 5 - (**110 Vdc**). If voltage is missing go to step 7b. If present, continue.

3. Defeat the **limit switches** on the Servo drive by removing the limit switch connector and lifting the limit switch defeater switches to the ON position. If no, continue.

4. Check **Fibers** - Check for breaks and tight radius bends. Verify fibers are connected snug to the circuit board by snapping them into their sockets. Each fiber has a blue end and a gray end, check for missing signals by observing red light at the blue end of each fiber. See Diagram 2! If missing, see note 1. If not, continue.

5. **Check for missing DC +** voltage, on pins 9 & 10 on the Servo Drive card you should measure 80 - 150 Vdc (Ideally 110 Vdc). If voltage present, replace Drive. If no, continue.

6. **Reset Spindle OCR4** (Non-Inverter units), and E-Stop Switch. Test, If no, continue.

7. Isolate Servo E-Stop Loop -

1. With power off, Jumper across pin 7 and pin 8 on the Servo Drive, and release the E-Stop. With a continuity meter, confirm continuity of the E-stop loop within the console at pins 6 and 2 of the main power cable . . . If no, determine where the open in E-Stop loop is. If yes, continue

2. Using Diagram 4 and a continuity meter, find any faulty components or connections that is causing an open in the E-Stop loop. Repair or replace as necessary.

Still Stumped? Send us these results . . .

1. LED Status lights - fill in the LED's that were NOT LIT

Drive type 1

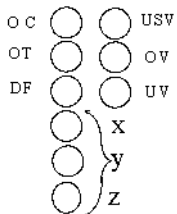

Drive type 2

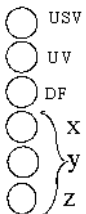

Legend:

OC	Over Current
OT	Over Temp.
DF	Drive Fault
USV	Under Switcher Voltage
UV	Under Voltage
OV	Over Voltage

Notes:

1. **Improper Estop action or no RED light** at the fibers means the Controls software is NOT talking to the PLC and should be checked - Confirm "Absent" is not selected on the Control setup screen under "PLC Type" (F1 - Setup; F3 - Config; F1 - Control)

2. If no LED's are lit, check for Logic Power from the TOKO supply mounted in the console Check connections, output voltages, wires.

If these procedures were followed, Power up the control and test again. If problem is still not solved, then call Tech Support with the results of these tests, please have your serial # ready.

Cord from Power Box

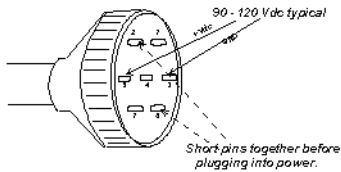

Pull here to remove!!

Do NOT pull on the cable

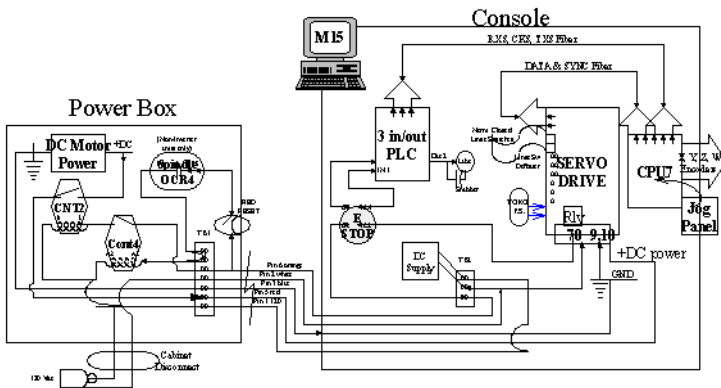
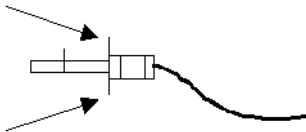

E-Stop Loop - (Break Down)

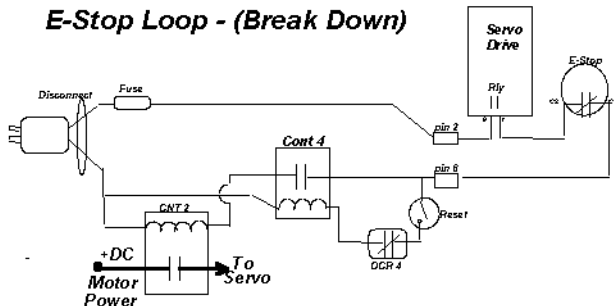

Document History

Rev1 Created on 2000-01-06