

# TB151 (Rev2) - M39 Upgrading to Spindle Inverter

## Overview

This document describes how to upgrade an existing M39 to an M39 with a variable spindle control.

## Materials List

Part Number	Part Description
10142	Spin232, DB9TXS connector and fiber optic cable
1331	Cosel Power supply w/ metal cover and cables
3923	Estop Piggyback contactor
	Wire required to connect components

1. Connect the Cosel power supply and Spin232 (rev. B) according to this diagram.

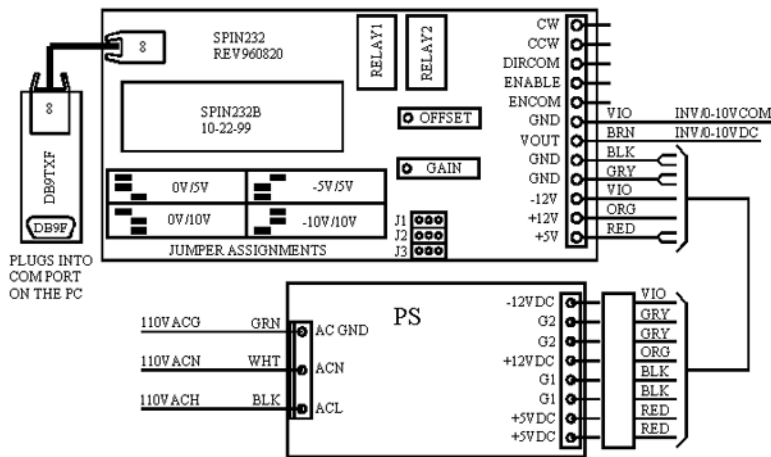

Or connect the Cosel PS and Spin232 (rev. C) according to this diagram.

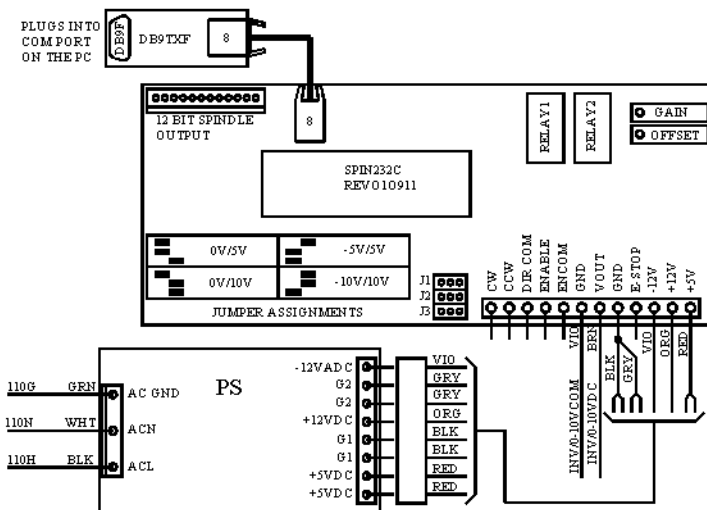

2. Make sure the jumpers are set correctly for the 0-10V on the Spin232 (both rev.'s).

3. Now connect the VOUT terminal of the SPIN232 board to the 0-10V input of your inverter and the GND right below VOUT to the inverter common.

- Connect the E-Stop terminal of the Spin232C to the E-Stop input of the PLC only if the PLC shares the same power supply as the Spin232C and the input common is GND. If not then you will need to connect a jumper between the E-Stop and GND terminal of the Spin232C.
- Mount the Estop piggy back to the Estop contactor. Connect it and the rest of the inverter connections to the PLC 15/15 according to the diagram below.

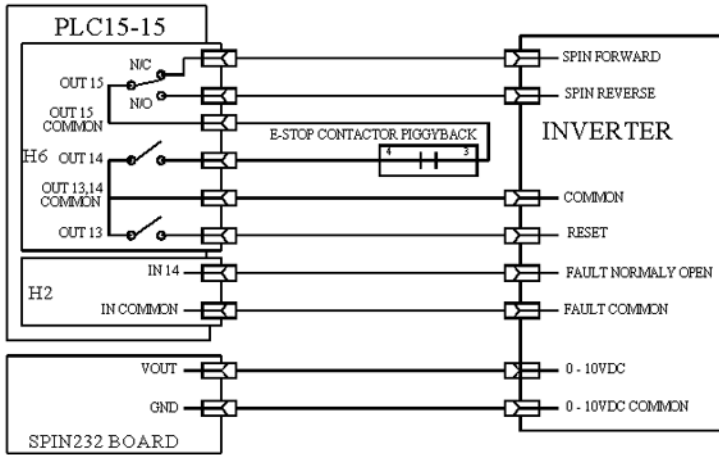

- Install the DB9TXS (fiber optic) adapter to the serial port (COM1 or COM2) on the back of the PC and plug the fiber optic cable into the adapter and the fiber optic socket on the SPIN232 board.
- Parameter 31 for spindle speed output port must be set to a 1 if the DB9TXS connector is plugged into COM1 of the PC or 2 if connected to COM2. Parameter 32 for the baud rate must be set to 19200.

---

### Document History

Rev2 Created on **2008-11-11** by **#300**

[Rev1](#) Created on **2002-11-04**