

Title: ACORN_rev3, KBIC DC MOTOR CONTROL FOR UP TO 1.5HP SPINDLE MOTOR		
Date: 180425	Ver: 4	Drawn by: CEM
Filename: S14895.DWG	Sheet 1 of 1	

How to tell the difference between Acorn_rev2 and Acorn_rev3
 Acorn_rev2 has FIXED green screw terminal blocks
 Acorn_rev3 has REMOVABLE green screw terminal blocks

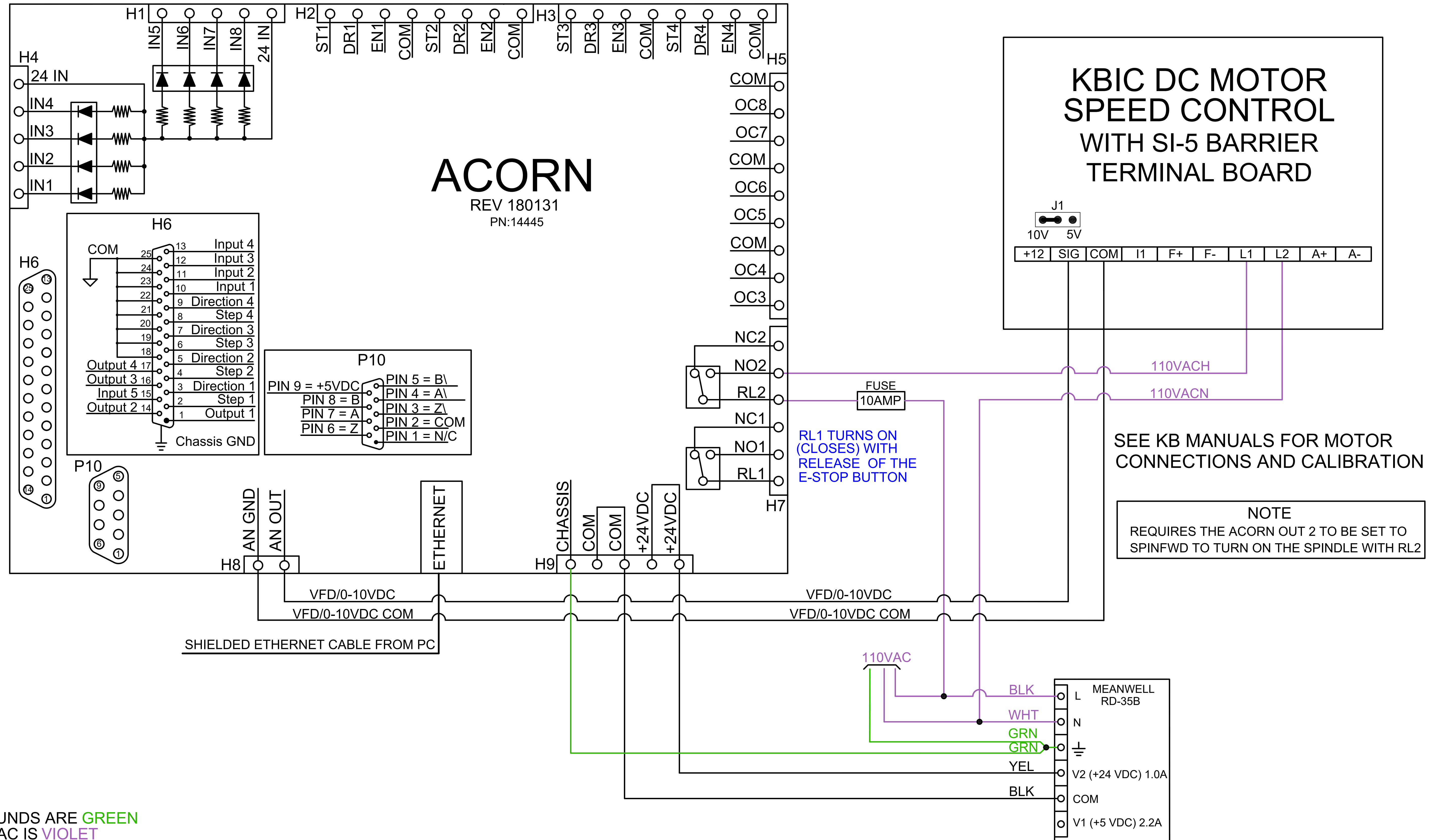

GROUNDS ARE GREEN
 110VAC IS VIOLET