

How to tell the difference between Acorn_rev2 and Acorn_rev3
 Acorn_rev2 has FIXED green screw terminal blocks
 Acorn_rev3 has REMOVABLE green screw terminal blocks

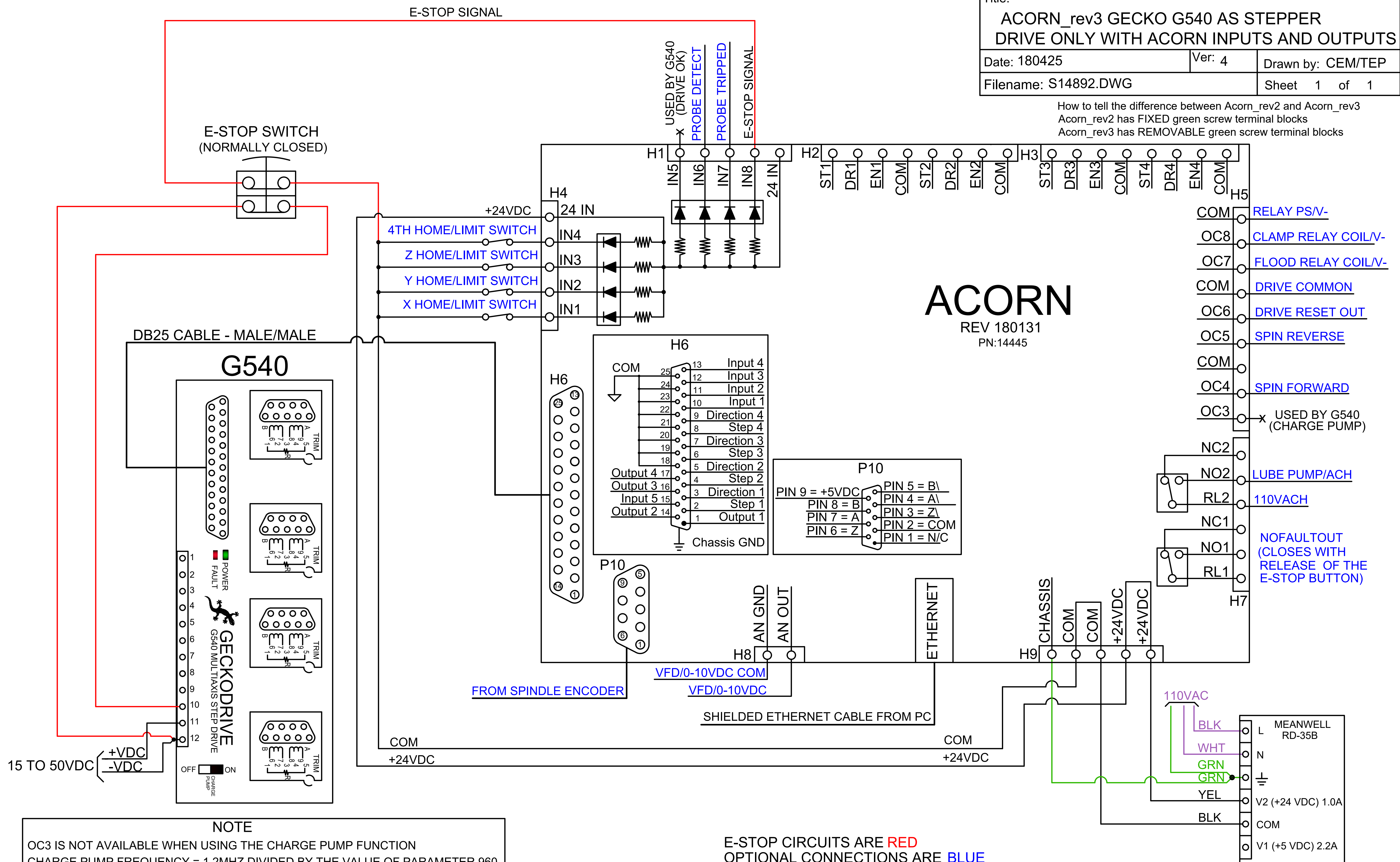

ACORN
 REV 180131
 PN:14445

NOTE
 OC3 IS NOT AVAILABLE WHEN USING THE CHARGE PUMP FUNCTION
 CHARGE PUMP FREQUENCY = 1.2MHZ DIVIDED BY THE VALUE OF PARAMETER 960
 A VALUE OF 0 IN PARAMETER 960 DISABLES THE CHARGE PUMP FUNCTION.

E-STOP CIRCUITS ARE RED
 OPTIONAL CONNECTIONS ARE BLUE
 GROUNDS ARE GREEN
 110VAC IS VIOLET