

How to tell the difference between Acorn_rev2 and Acorn_rev3
 Acorn_rev2 has FIXED green screw terminal blocks
 Acorn_rev3 has REMOVABLE green screw terminal blocks

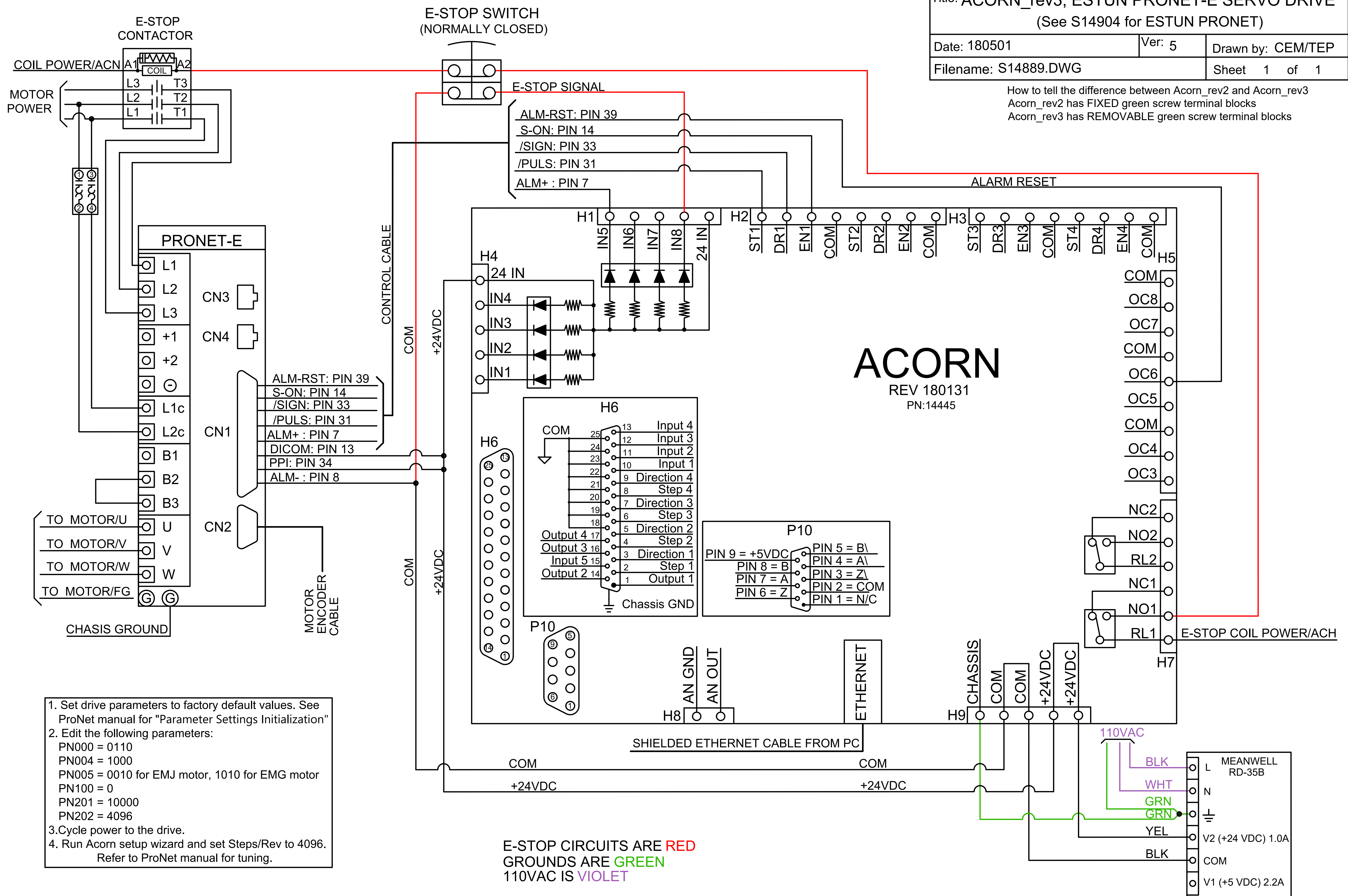

1. Set drive parameters to factory default values. See ProNet manual for "Parameter Settings Initialization"
2. Edit the following parameters:
 PN000 = 0110
 PN004 = 1000
 PN005 = 0010 for EMJ motor, 1010 for EMG motor
 PN100 = 0
 PN201 = 10000
 PN202 = 4096
3. Cycle power to the drive.
4. Run Acorn setup wizard and set Steps/Rev to 4096. Refer to ProNet manual for tuning.

E-STOP CIRCUITS ARE RED
 GROUNDS ARE GREEN
 110VAC IS VIOLET