

DETAIL

NO SCALE

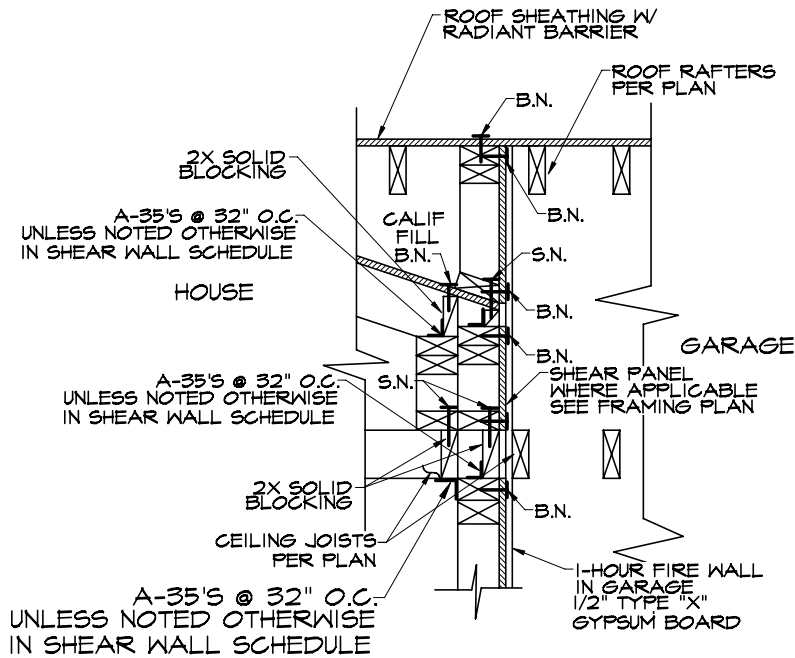

DETAIL

NO SCALE



PROJECT ADDRESS:
 7803 PURITAN ST.
 DOWNEY, CA 90242
PROJECT COORDINATOR:
 BILL GRIFFIN
 562-477-2054

**GRIFFIN PROPERTY
 REVISED DETAILS**

FIGURE
1
 OF **1**

DATE: 11-22-09