

EW, EWO, MW, MWO, PW, & PWO Warming Ovens



Revised
11/29/07

24", 27", 30", 36" Wide,
Warming Ovens

1/2

**PLANNING
GUIDE**

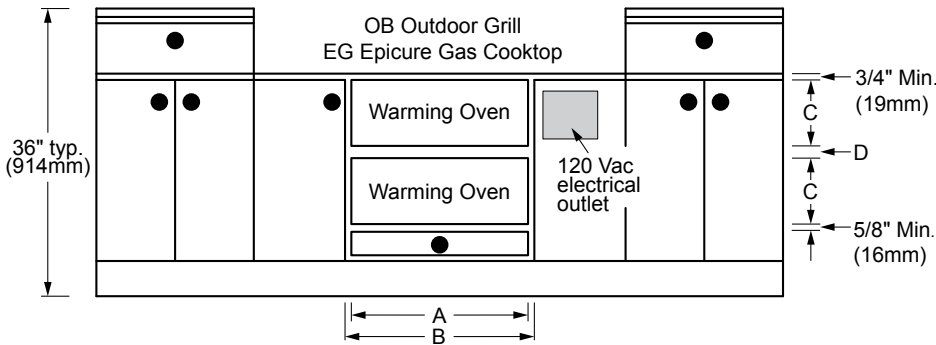
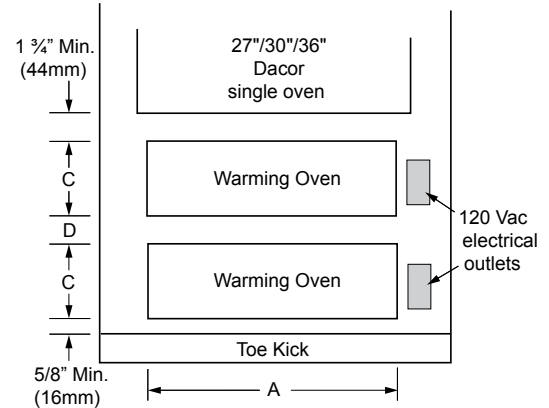
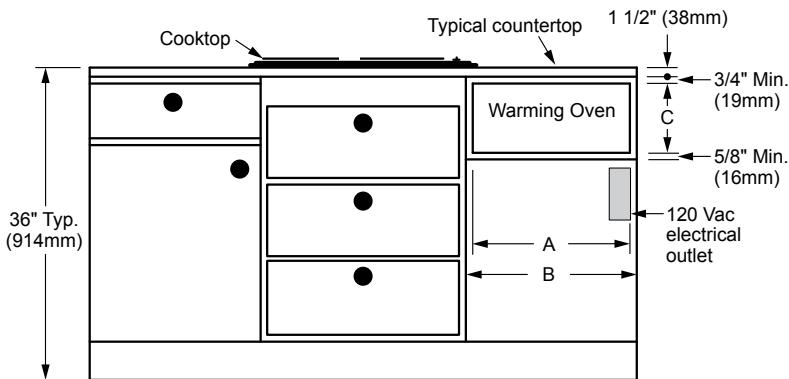

Model	"A" Cutout Width	"B" Min. Width to Adjacent Doors/Drawers	"C" Cutout Height	"D" Min. Gap Between Cutouts
EWO24	22 1/2" (572mm)	24 1/4" (616mm)	9 1/8" (232mm)	1 1/16" (27mm)
EW27	25 1/2" (648mm)	27 1/4" (692mm)		
EWO27				
MW27				
MWO27				
PW27				
EW30				
EWO30				
MW30				
MWO30				
PW30				
PWO30				
EWO36	34 3/8" (873mm)	36 1/4" (921mm)	3" (76mm)	

CUTOUT DIMENSIONS

NOTES:

1. EWO36 models cannot be stacked.
2. 23 3/8" (594mm) minimum cabinet depth.
3. 3/4" (19mm) support platform (flush with cutout).
4. See the Combination Installation (CI) Section if installing with a wall oven, microwave, or cooktop.
5. For stacked warming ovens, see CI.24.

EW, EWO, MW, MWO, PW, & PWO Warming Ovens



Revised
11/29/07

24", 27", 30", 36" Wide,
Warming Ovens

2/2

**PLANNING
GUIDE**

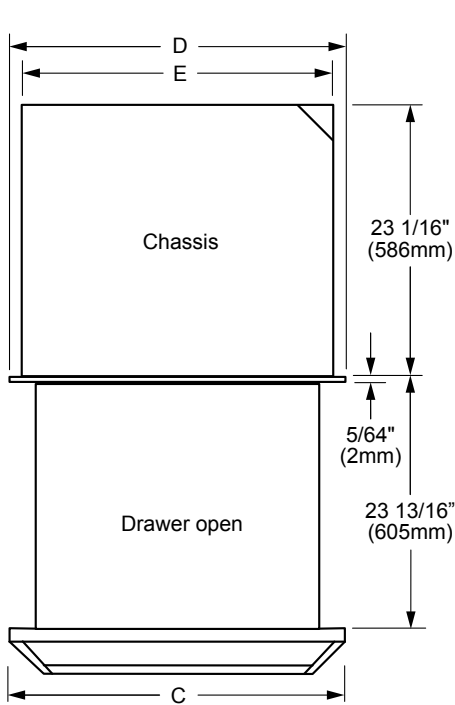

**OVERALL DIMENSIONS
TOP VIEW
(EWO Shown)**

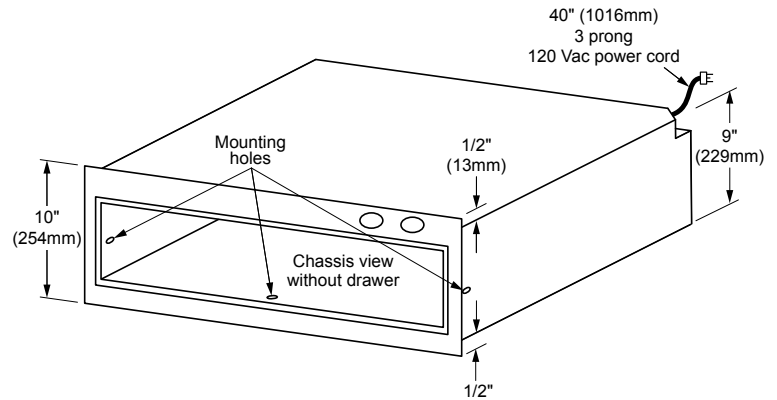

**OVERALL CHASSIS DIMENSIONS
(Chassis View Without Drawer)**

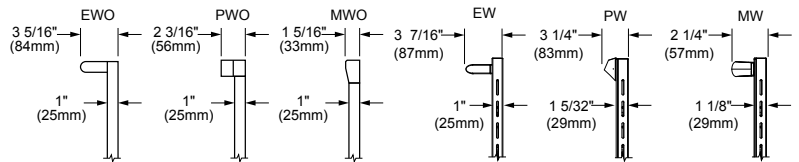

SIDE VIEW HANDLE PROJECTIONS

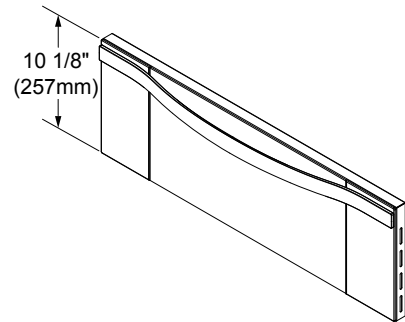

**DRAWER FACE DIMENSIONS
(MW Shown)**

Models	Dedicated Circuit Required	Total Connected Load	Approximate Shipping Weight
24"	120VAC, 60Hz, 15A (Breaker)	0.5kW (4A)	70 lbs.
27"			73 lbs.
30"			76 lbs.
36"		0.8kW (6.5A)	90 lbs.

Model	"C" Drawer Face Width	"D" Chassis Face Width	"E" Chassis Width
EWO24	23 7/8" (606mm)	23 11/16" (602mm)	22 3/16" (564mm)
EW27	26 7/8" (683mm)	26 11/16" (678mm)	25 3/16" (640mm)
EWO27			
MW27			
MWO27			
PW27	29 7/8" (759mm)	29 11/16" (754mm)	25 3/16" (640mm)
EW30			
EWO30			
MW30			
MWO30			
PW30			
PWO30	35 7/8" (411mm)	35 11/16" (906mm)	34 1/4" (870mm)
EWO36			