

ESG366, ESG486



36 Inch and 48 Inch Wide Epicure® Gas Cooktops

PLANNING GUIDE

⚠ WARNING

- Observe all governing codes and ordinances during planning and installation. Contact your local building department for further information.
- This appliance must be installed in accordance with the accompanying installation instructions.

Product tolerances: ±1/16" (±1.6 mm) unless otherwise noted

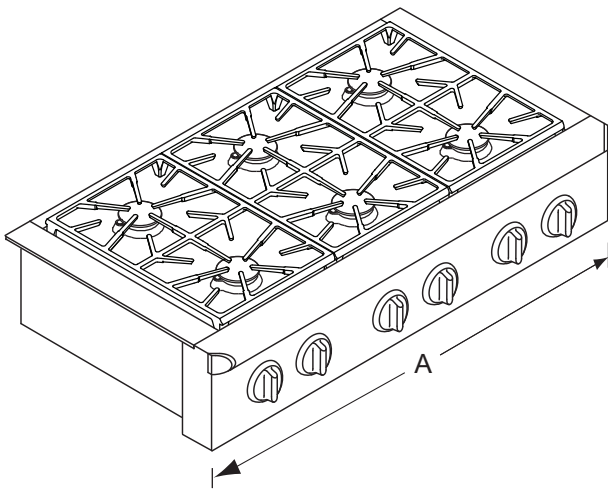

PRODUCT DIMENSIONS

A - Width	
ESG366	35 7/8" (911 mm)
ESG486	47 7/8" (1216 mm)

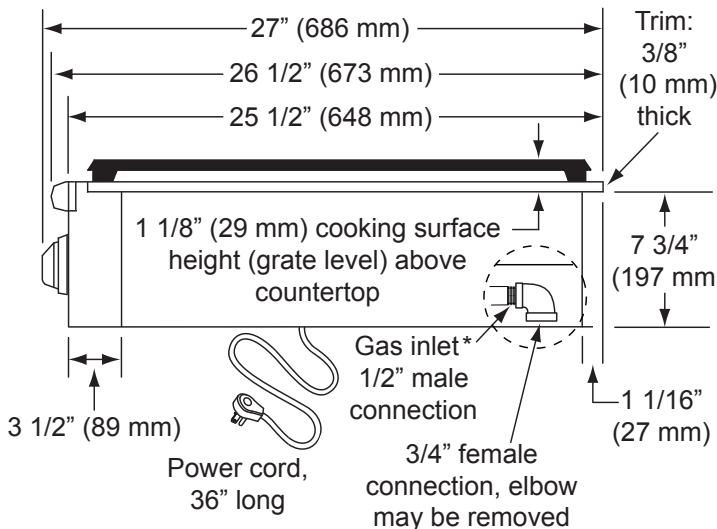

*Attach supplied regulator and gas line from bottom or rear of unit

SIDE VIEW

ELECTRIC CIRCUIT REQUIREMENTS	
Circuit Required	Total Connected Load
120 Vac 60Hz, 15 Amp. (3 wire)	0.25 Amp @ 120 Vac, 60 Hz

GAS SUPPLY PRESSURE REQUIREMENTS*		
Gas Type	Manifold Pressure	Minimum Gas Supply Pressure
Natural Gas	4" Water Column	5" Water Column
Propane (LP)	10" Water Column	11" Water Column

* Maximum gas supply pressure for all models is 1/2 p.s.i.

IMPORTANT: Installation of a non-combustible material* (up to the hood) or a backsplash is always recommended, and mandatory if the distance to the back wall from the cooktop is less than 2 1/2" (Figure 2). When installing a backguard, use only Dacor model numbers AEB3609, AEB3612 (EG366), AEB4809 or AEB4812 (EG486).

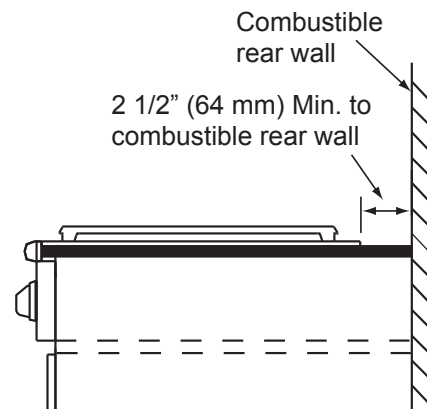

CABINET/COUNTERTOP - SIDE VIEW WITHOUT BACKGUARD

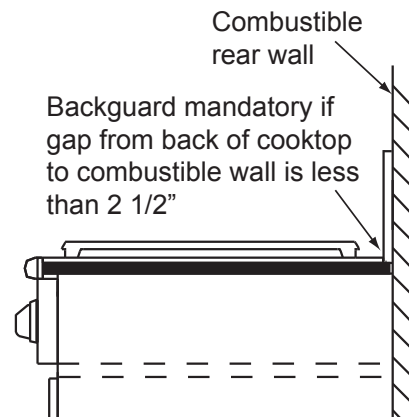

CABINET/COUNTERTOP - SIDE VIEW WITH BACKGUARD

ESG366, ESG486



36 Inch and 48 Inch Wide Epicure® Gas Cooktops

PLANNING GUIDE

Cabinet tolerances: +1/16", -0 (+1.6 mm, -0) unless otherwise noted.

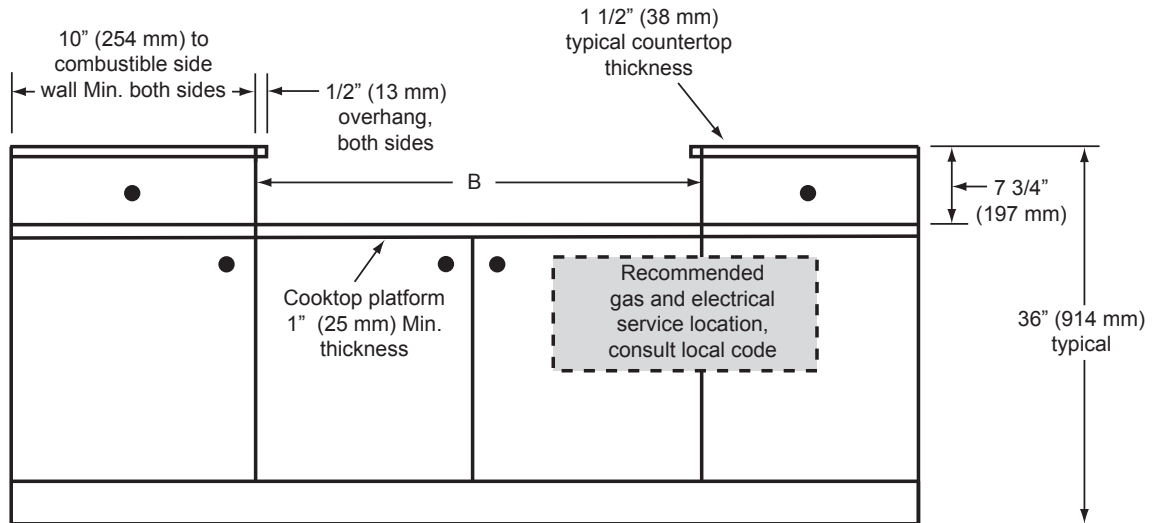

CABINET/COUNTERTOP DIMENSIONS - FRONT VIEW

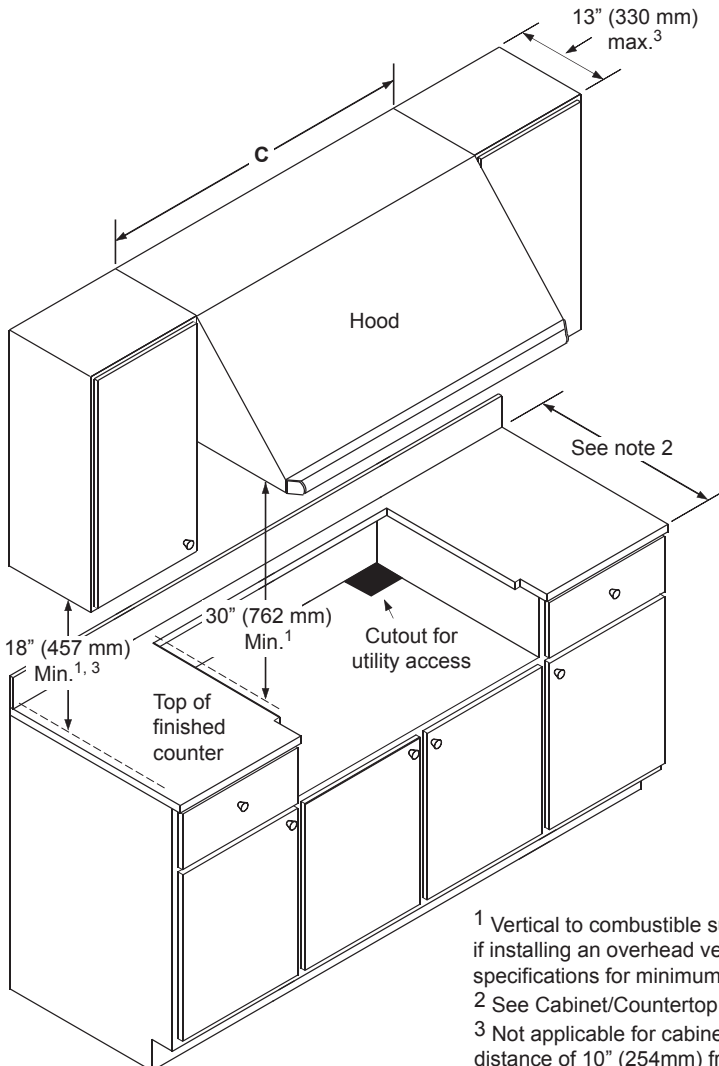

Model No.	B	C
ESG366	36" (914 mm)	36" (914 mm)* 42" (1067 mm)**
ESG486	48" (1219mm)	48" (1219 mm)* 54" (1372 mm)**
* Minimum ** Recommended		

CABINET/COUNTERTOP DIMENSIONS - ISO VIEW

1 Vertical to combustible surface from cooktop grate level; if installing an overhead vent hood, also check the hood specifications for minimum required clearances.

2 See Cabinet/Countertop Dimensions - Top View

3 Not applicable for cabinets more than a horizontal distance of 10" (254mm) from the edge of the cooktop.

Continued. on following pages...

ESG366, ESG486



36 Inch and 48 Inch Wide Epicure® Gas Cooktops

PLANNING GUIDE

Cutout tolerances: +1/16", -0, (+1.6 mm, -0) unless otherwise stated

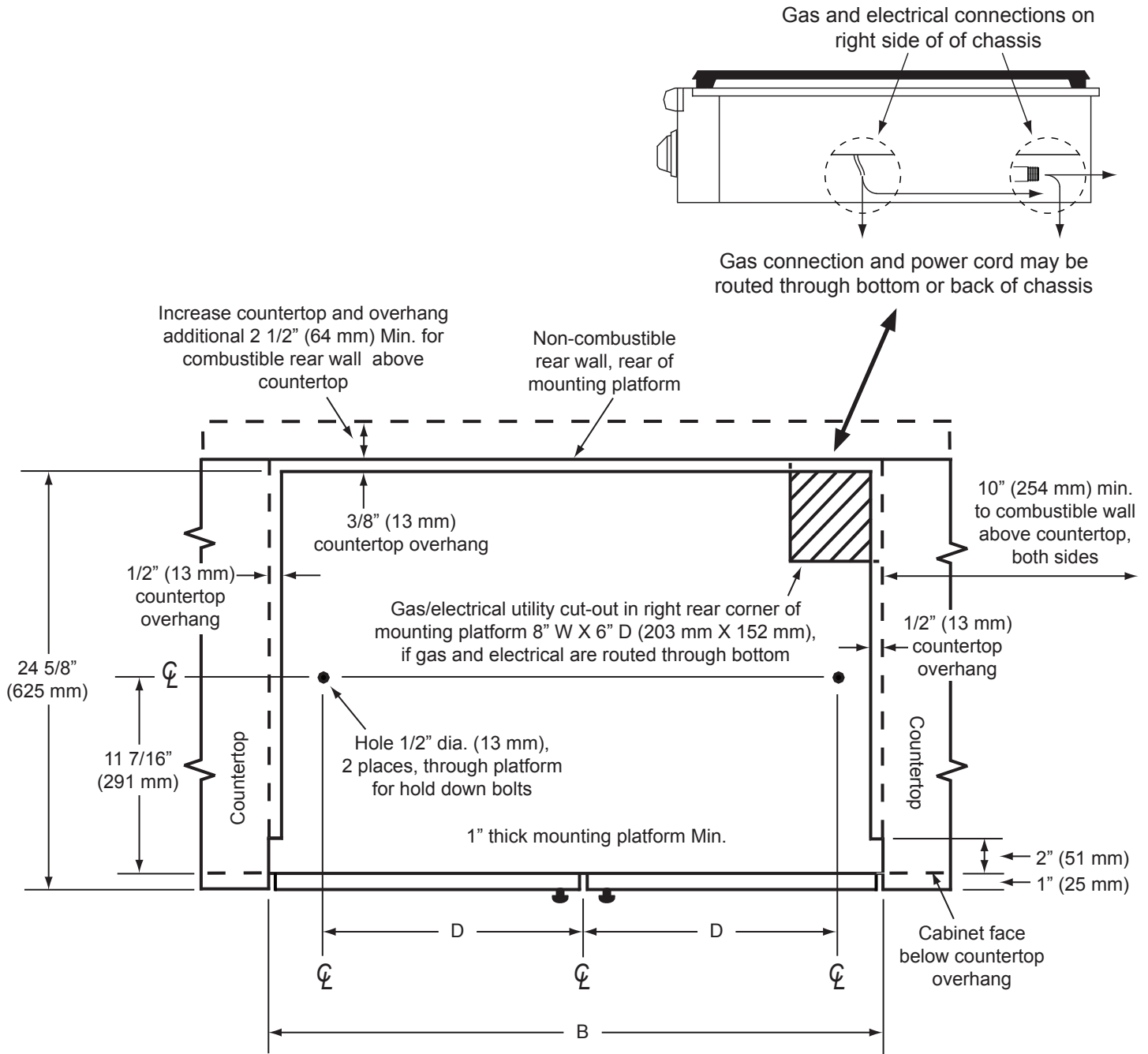

CABINET/COUNTERTOP CUTOUT DIMENSIONS WITHOUT RAISED VENT - TOP VIEW

Model No.	B - Cutout Width	D - Hole Offset
ESG366	36" (914 mm)	16 5/8" (422 mm)
ESG486	48" (1219 mm)	20 13/16" (529 mm)

ESG366, ESG486



36 Inch and 48 Inch Wide Epicure® Gas Cooktops

PLANNING GUIDE

Cutout tolerances: +1/16", -0, (+1.6 mm, -0) unless otherwise stated

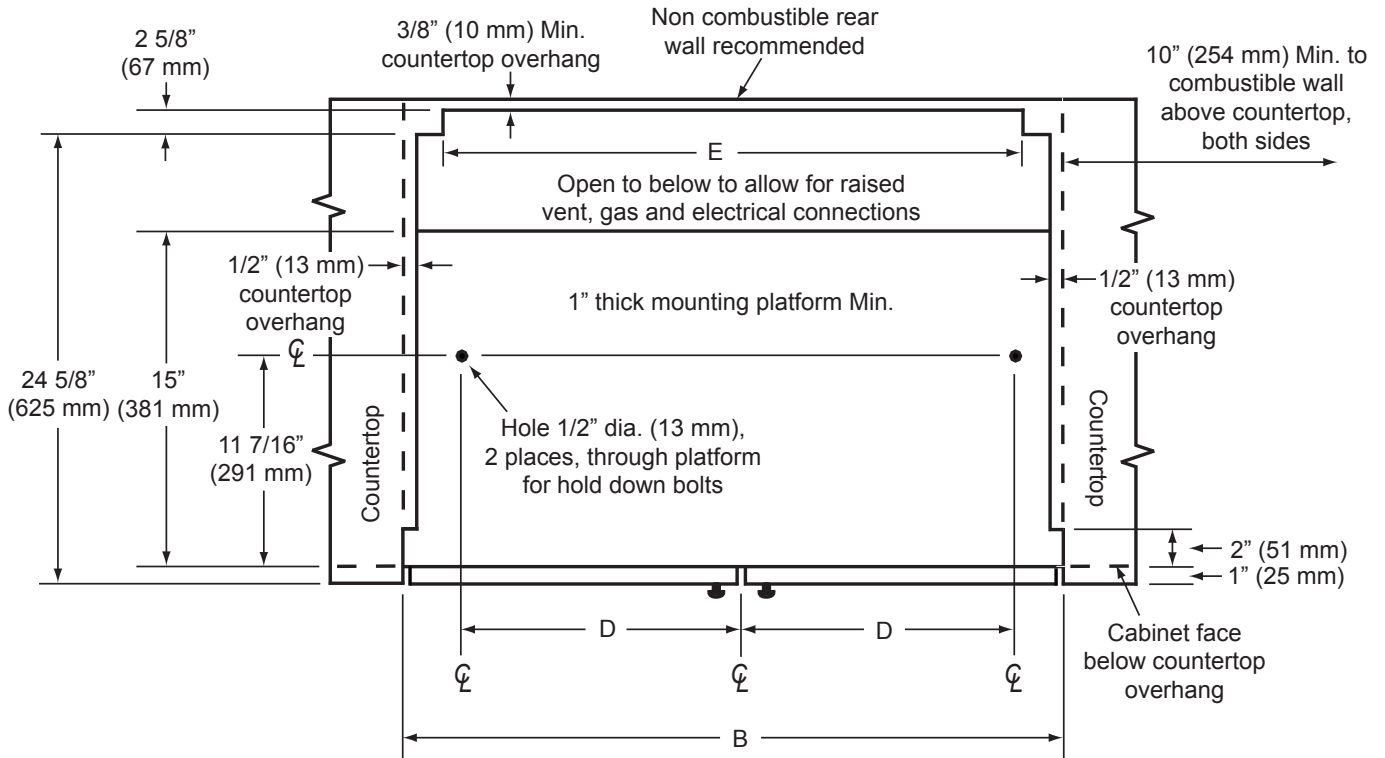

CABINET/COUNTERTOP CUTOUT DIMENSIONS WITH RAISED VENT - TOP VIEW

Model No.	Approved Raised Vent Models
ESG366	ERV36, PRV36
ESG486	ERV48, PRV48

IMPORTANT: Use only the raised vents specified.

Model No.	B - Cutout Width	D - Hole Offset	E - Raised Vent Cutout
ESG366	36" (914 mm)	16 5/8" (422 mm)	33 1/2" (851 mm)
ESG486	48" (1219 mm)	20 13/16" (529 mm)	43 1/2" (1105 mm)

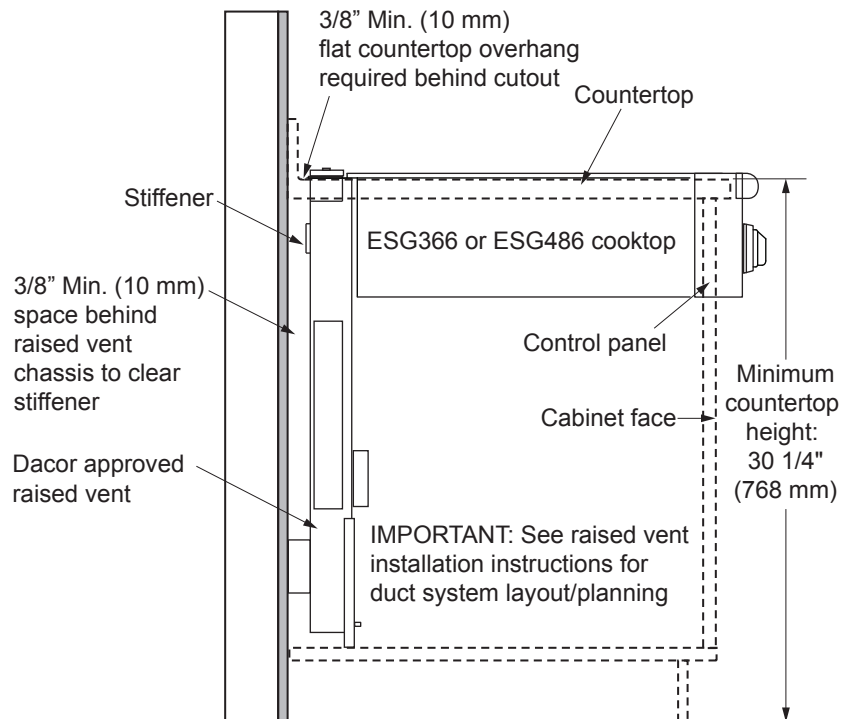

CABINET/COUNTERTOP CUTOUT DIMENSIONS WITH RAISED VENT - SIDE VIEW